

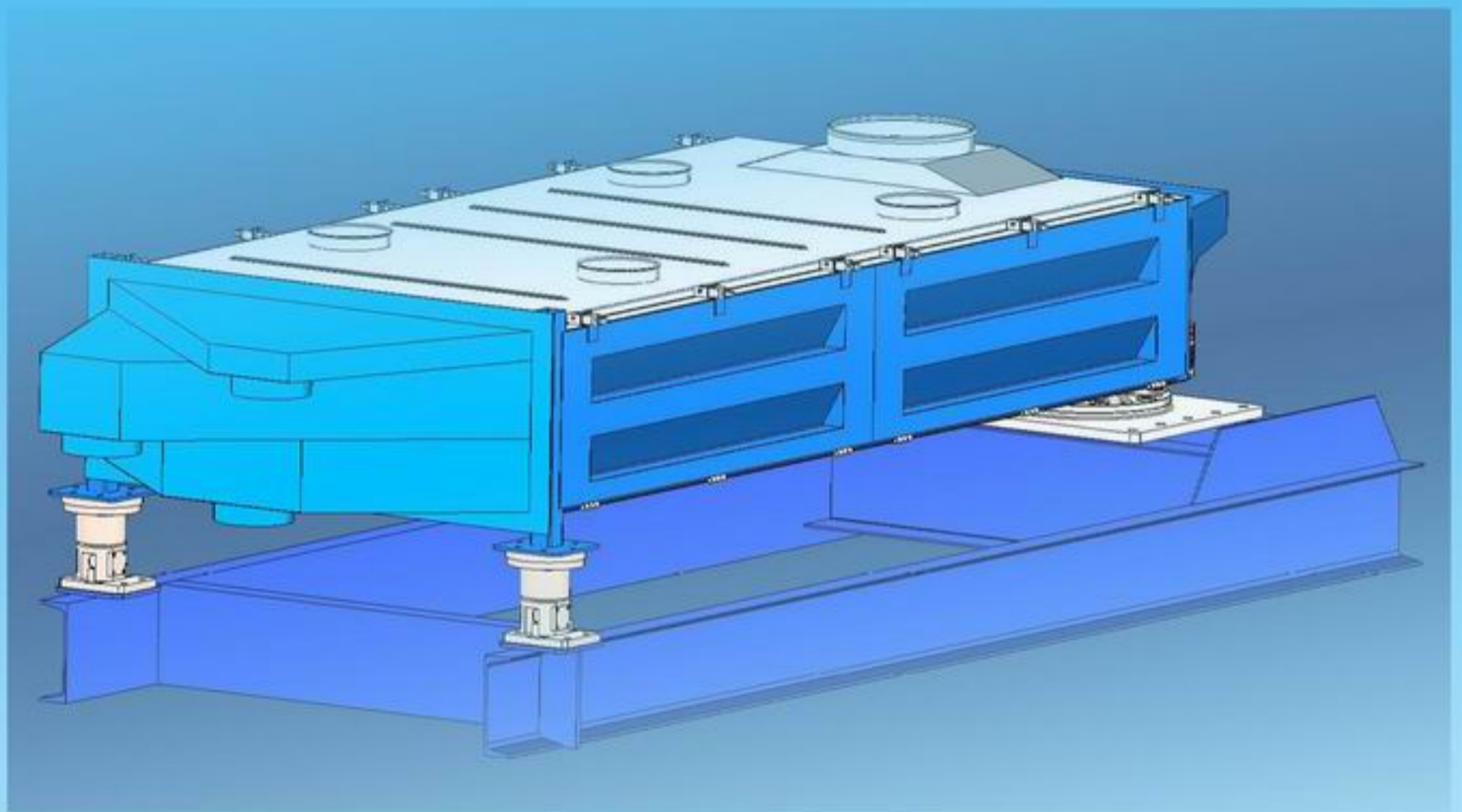

MEGA YOUNG SCREENING TECHNOLOGY CO.,LTD

MEGA YOUNG
兆 扬

兆扬筛分技术有限公司



MPG Series
Gyratory Screener



CONTENTS

- General
- Working principle
- Material flow
- Screener structure
- Screener installation
- Advantage
- Application
- Parameter
- Material data
- Our Service
- Factory



Henan Mega Young Screening Technology Co.,Ltd as one of Henan Pingyuan Mining Machinery Co.,Ltd is professional in researching and developing and selling M&Y gyratory screener, we have strong production capacity and plenty customer who applied our gyratory screener, so we believe we Mega Young Screening could offer you the proper screening solution and gyratory screener.

MEGA YOUNG SCREENING TECHNOLOGY CO.,LTD
河南兆扬筛分技术有限公司

Address: 2503,Unit B, Chamber of Commerce Building,
No.688, Jinsui East Road,
Xinxiang City, China

Factory Address: 289 Yellow River Road,
Xinxiang City, China

Tel:086-373 2698111/222

Email: info@megayoungscreener.com
gyratoryscreen@hotmail.com

Website: www.megayoungscreener.com



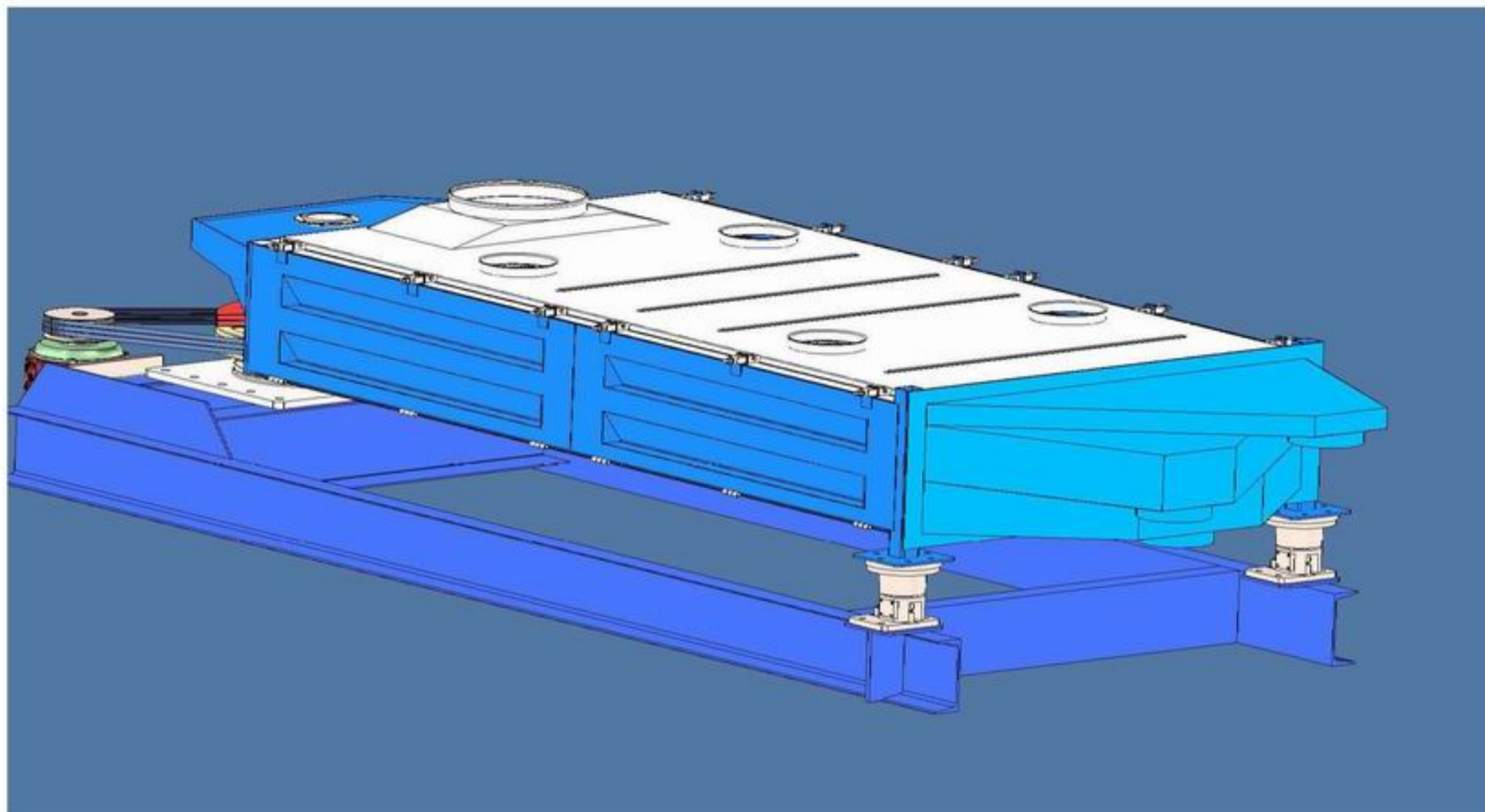

MPG Series screener is easy for operation and its structures is compact. It also screen the powder and little particle material via its reciprocating gyratory motion on one level plane. Less worker could do the operation, maintenance work for the screener because its special screen deck structure.

Its main features as following:

1. Screening precision is high and capacity is large
2. The job for renewing screener deck is simple
3. The room for installation, operation and maintenance is little.

Refer to above features, this catalogue will illustrate it clearly in the following pages.

The M&Y series Gyratory screener technology is our main target, studying and researching the effective screening solution for customer is our only purpose!

Working Principle

MPG series Gyrotory Screener is one kind of precision screener, which could screen particle material, powder material and irregularly shaped material. Compare with some other heavy duty screener, its screening precision is higher, compare with some other precision screener, its capacity is larger.

Right picture show how the gyrotory screener work with two layer mesh decks, the screener could separate the material into three size specification scope material. Our M series gyrotory screener could be with 1-4 layers of mesh deck.

Remark: Because this screener deck with low slop angle, so the projection size of screen mesh aperture to ground is similar with the fact screen mesh aperturesize, so the screened material could meet customer's request much more.

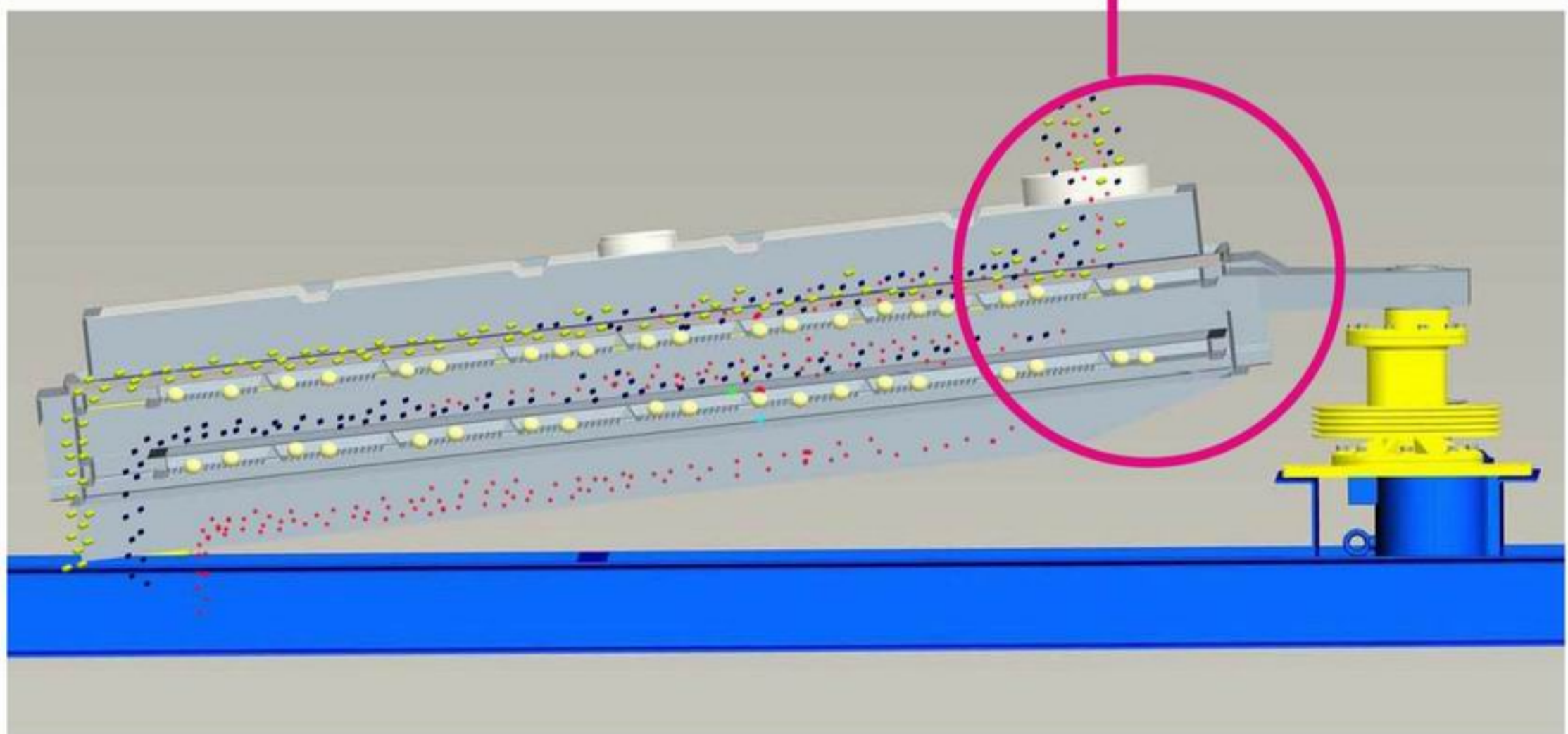
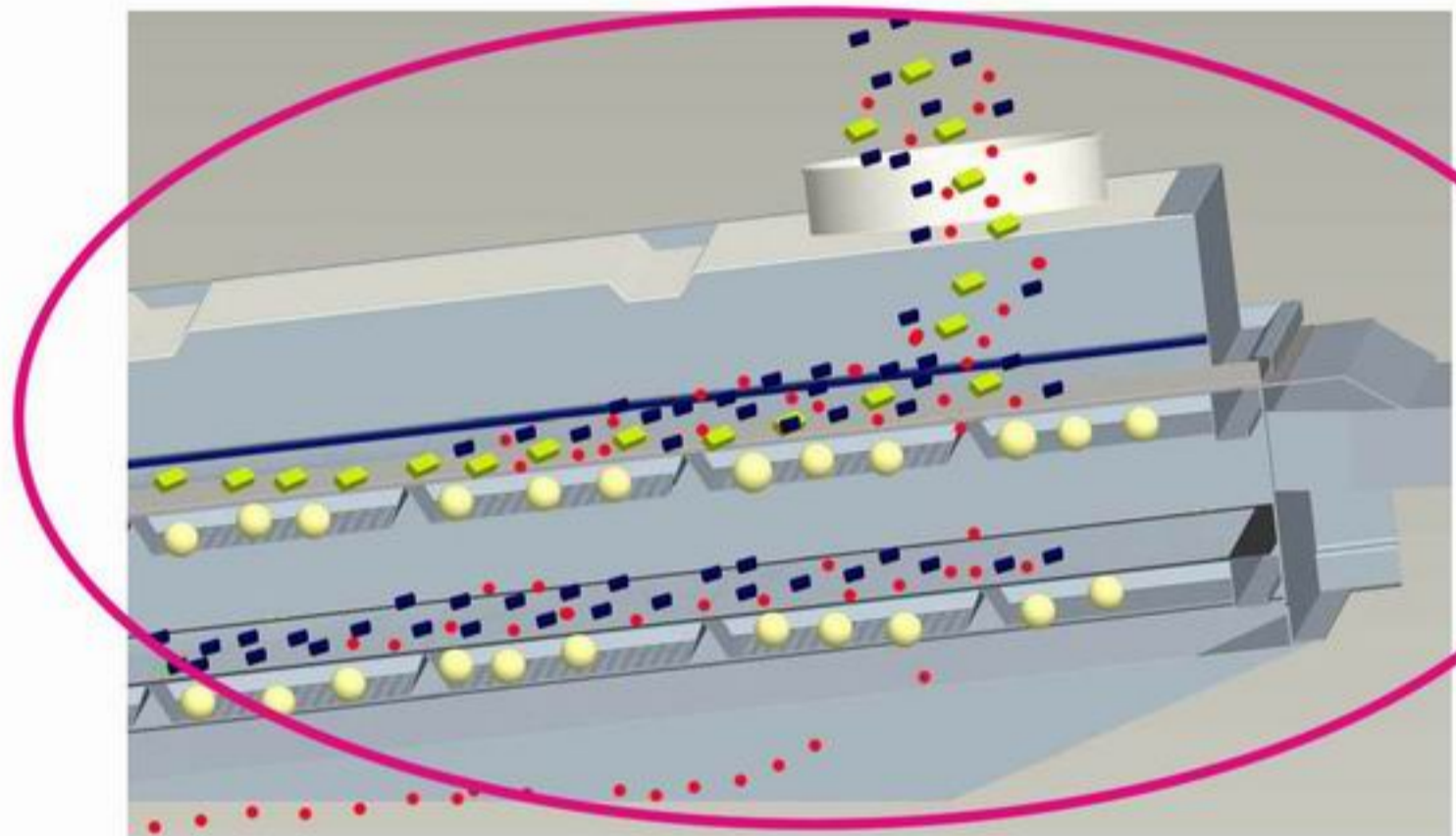

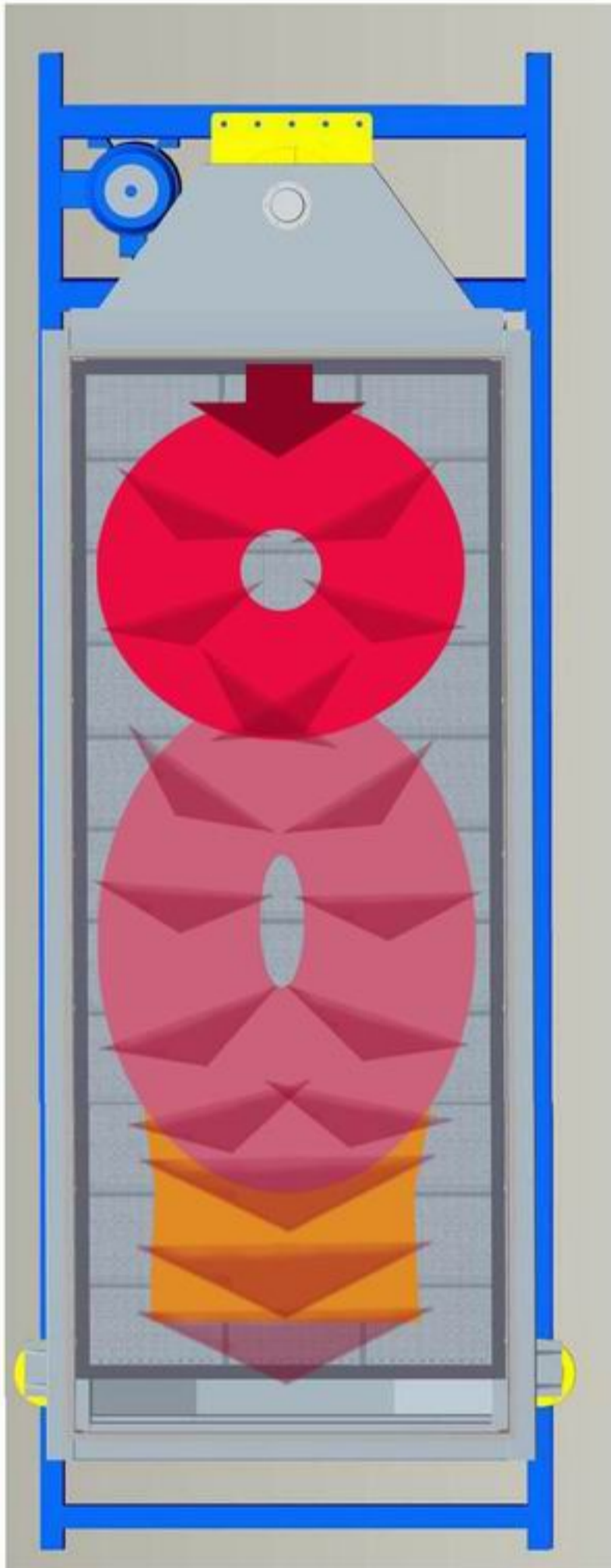

During screening, the material movement track is varied, we could take the complete screening process from feeding to outputting as three stages:

Stage 1: Under the screen box gyratory circular movement, the material will be distributed evenly on the whole width of the screen deck after material feed into the inlet of the screener, some little size material start pass through the screen deck. In this stage, it is mainly for distribute the material.

Stage 2: Along with the material flow toward the outlet, the material movement track will become elliptical. In this stage, the material bed has been cover the screen deck evenly, and the thickness is suitable for screening, so the equipment could screen the material adequately in this stage.

Stage 3: In this stage, the material flow has been near the screen outlet after stage 2, the material screening work almost be finished after previous 2 stages, the material movement track will become linear from elliptical gradually, the material movement distance will be shorter, so the material over screen aperture size will flow toward the outlet soon.



Stage 3
Flow out



Stage 2
Material distribute evenly



Stage 1
Material distribute at inlet

Screener structure



MPG Type Gyrotary screener consist of screener deck assembly, base support frame, tail rotary support and driving arrangement.

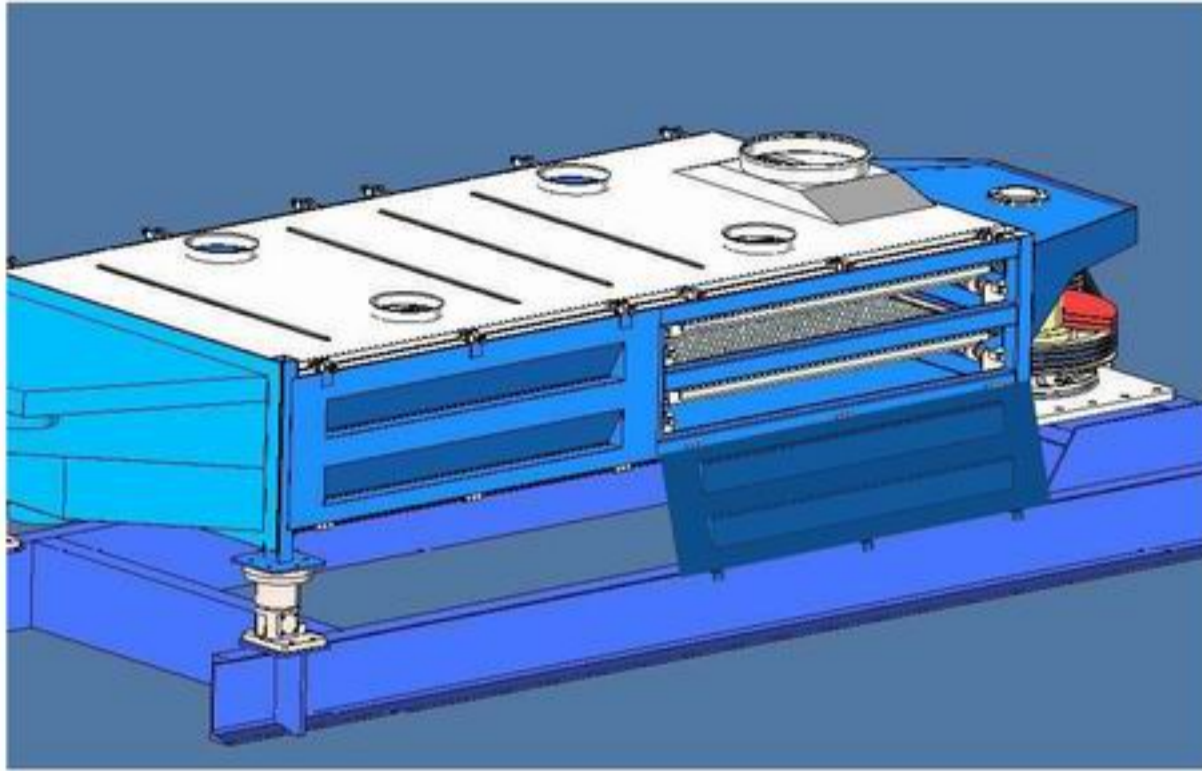

Driving arrangement: Include motor, rotary exciter, motor and exciter base.

Base support frame: it is support the screener box and rotary exciter.

Tail slide support: it is support screener box and limit the movement path.

Remark: Left picture is pedestal installation method, the customer could select suspension installation type if request

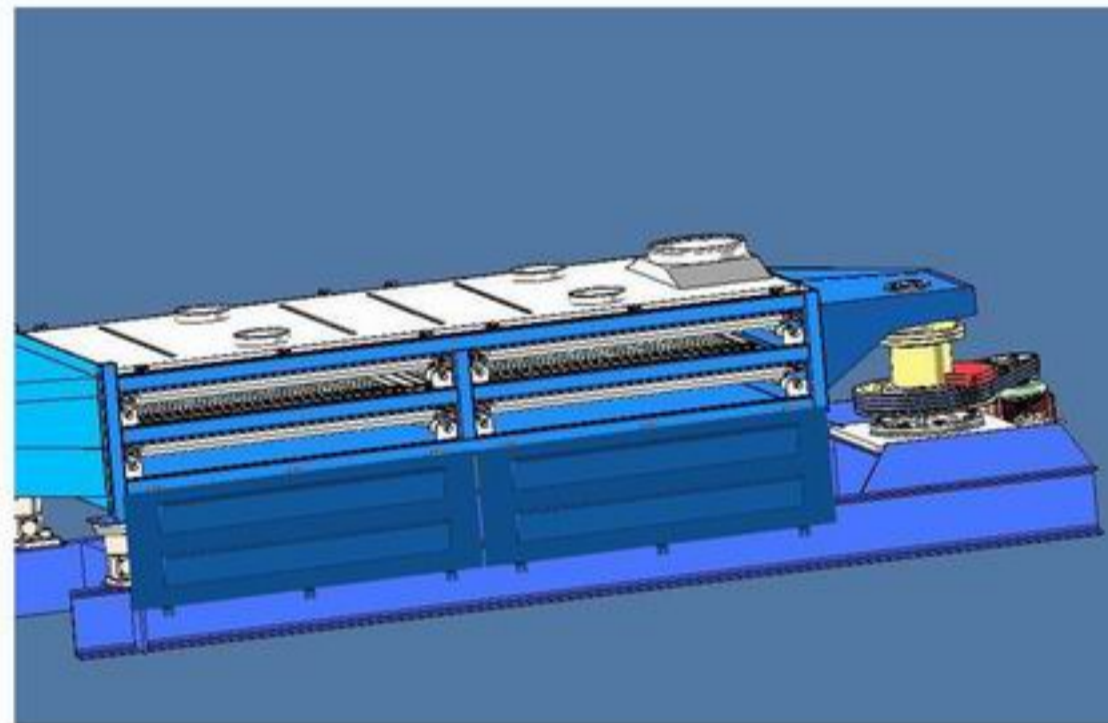
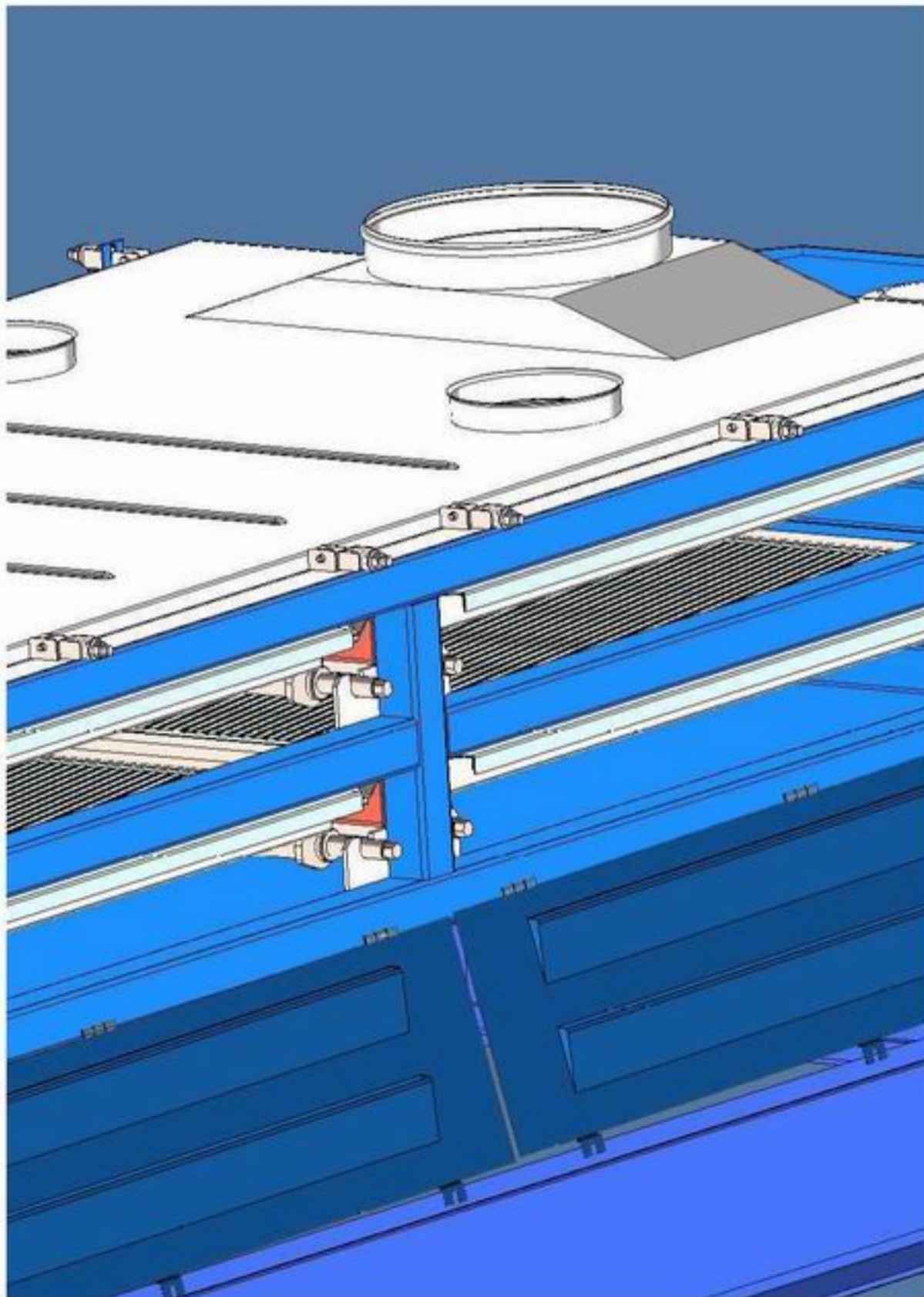

Screener box assembly: It consist of inlet and buffer&distribute device, screener box casing, screener side gate, fast clamp for side gate, screener deck assembly, screener deck fast fasten device.

The special design for screen deck structure, fasten device for deck and side gate structure could make you inspect the screener internal structure easily, and the customer also could renew and fasten the screen deck easily.

Screeener structure

Screeener deck structure

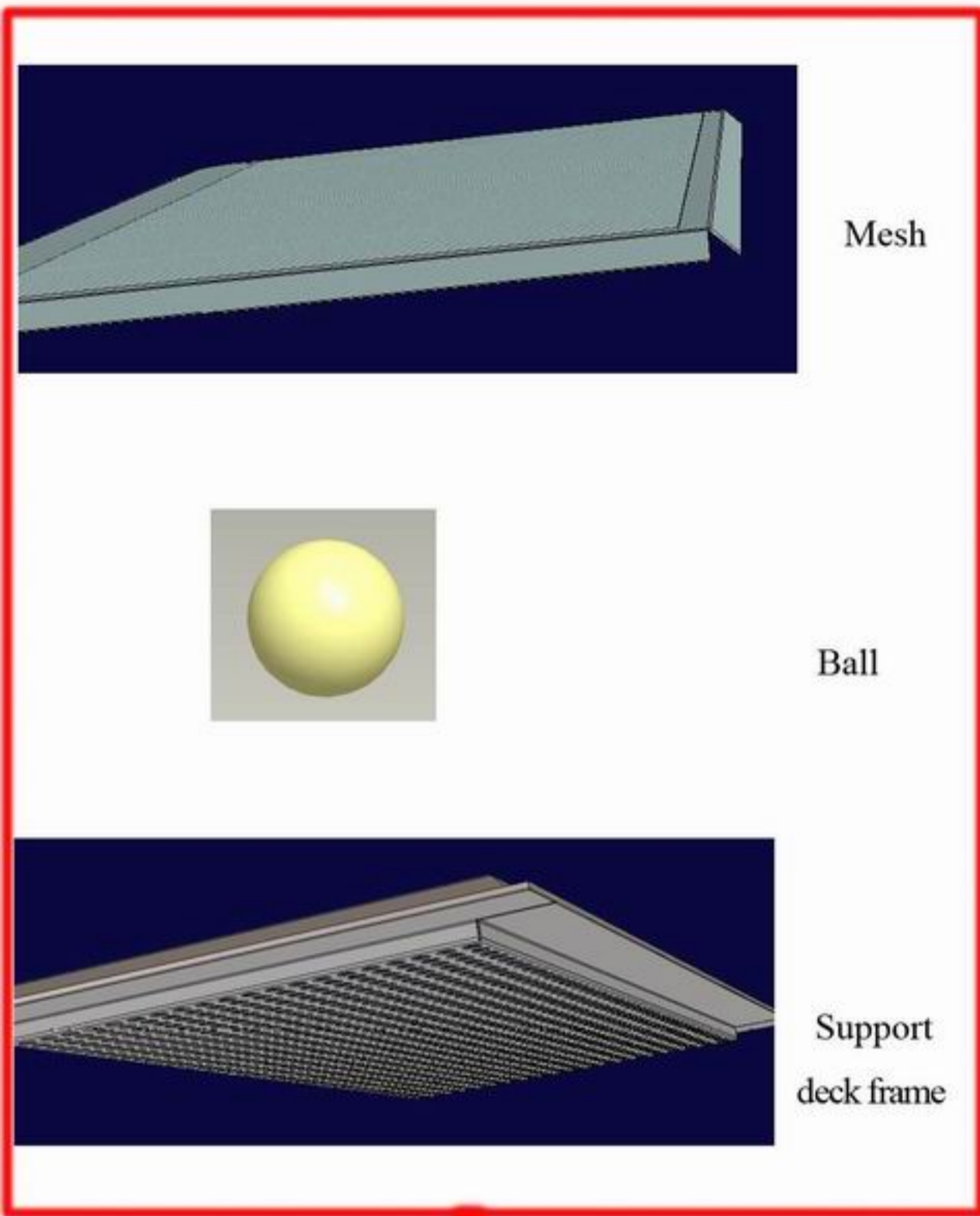

The screen deck of MPG series Gyrotory screener include working mesh, rubber ball and support deck frame, the working mesh , self-cleaning ball and support deck frame are independent with each other, the screen working mesh lay on the support deck frame, and there is no fasten device on the support deck frame, the self-cleaning ball is between the support deck and working mesh, the ball will jump up and down to hit the screen mesh for keeping from material blocked in the mesh aperture.

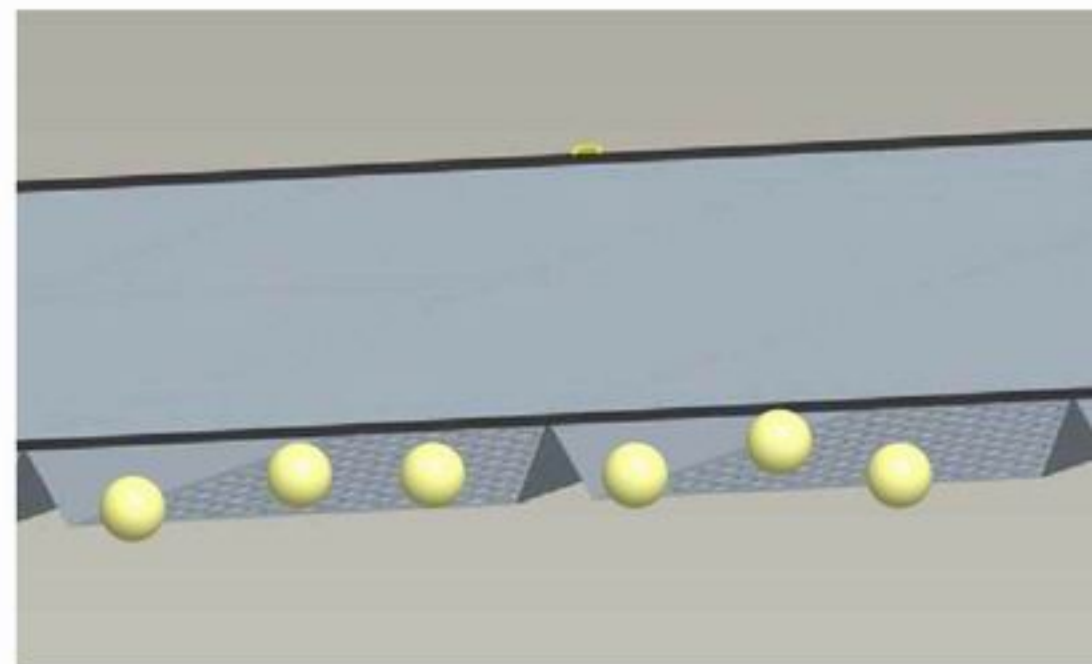
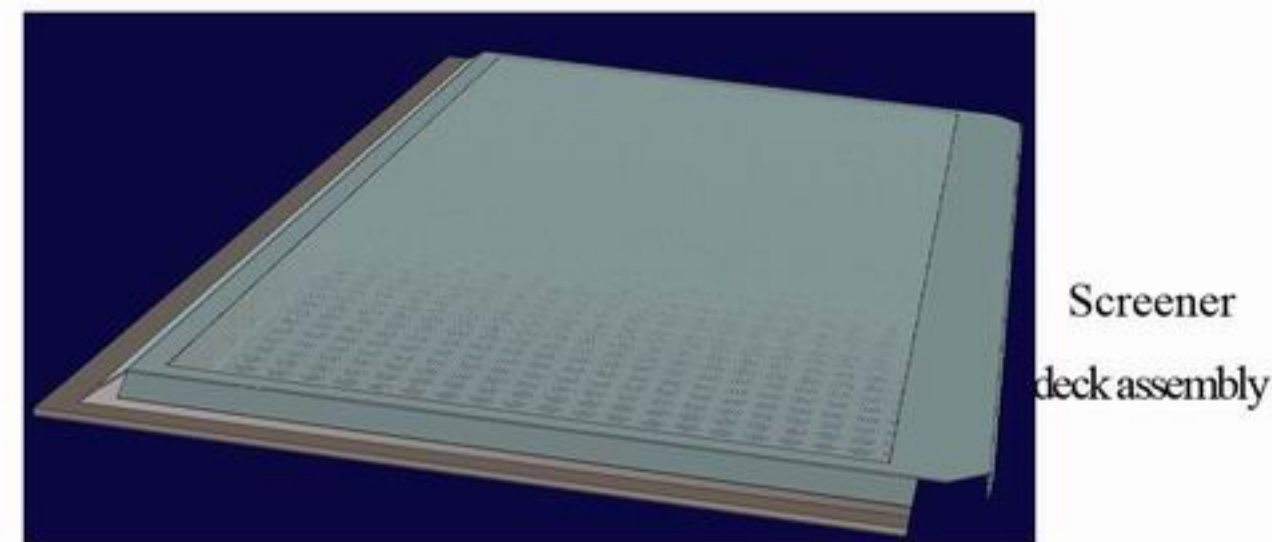

Screeener deck assembly sketch

Screen deck installation

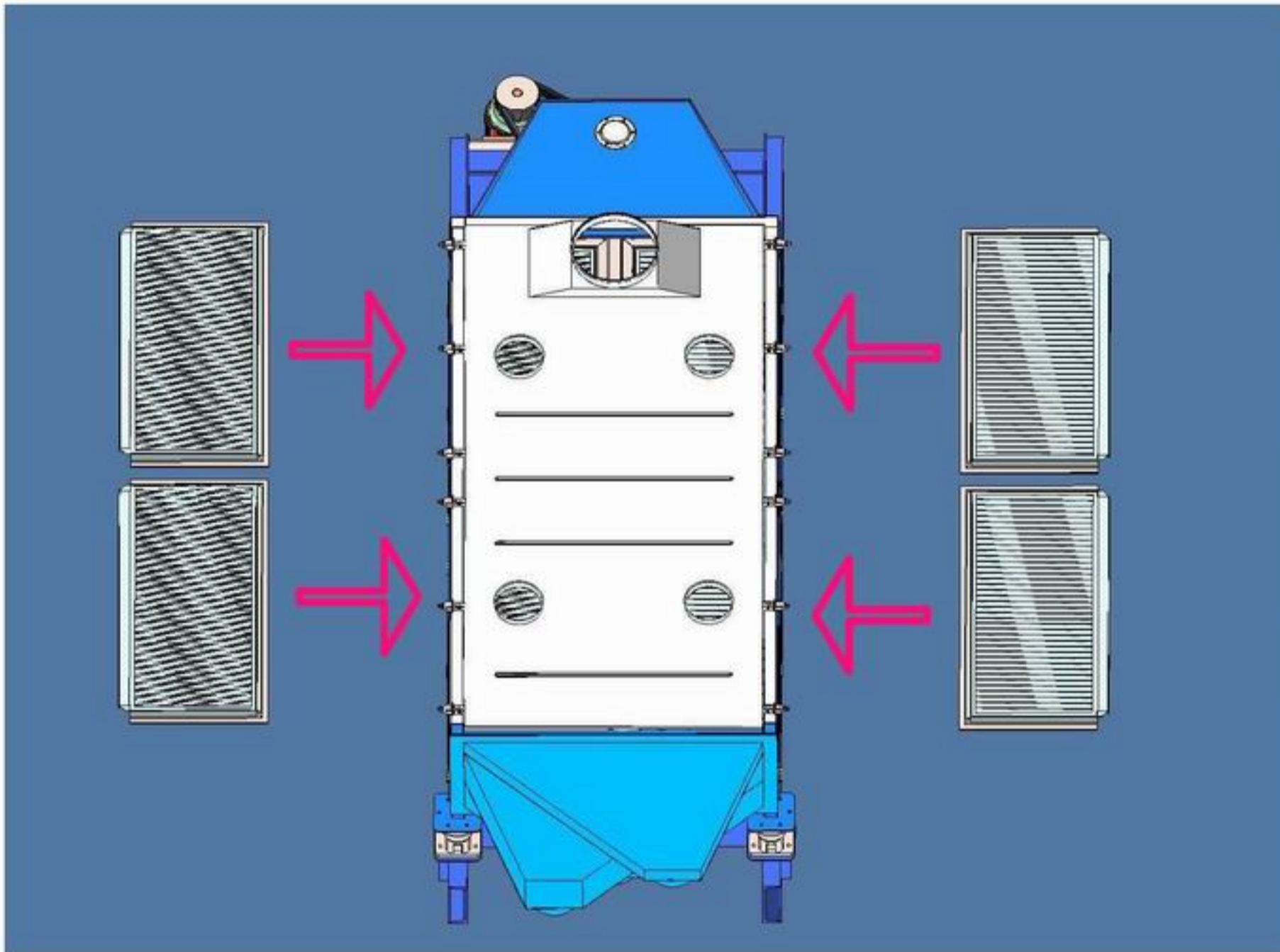

It is MPG gyratory screen deck installation drawing as left pictures.

Could set up the screen deck from two side of screener box at the same time.

Put the new screen mesh or changed screen mesh and self-cleaning ball on the support deck frame.

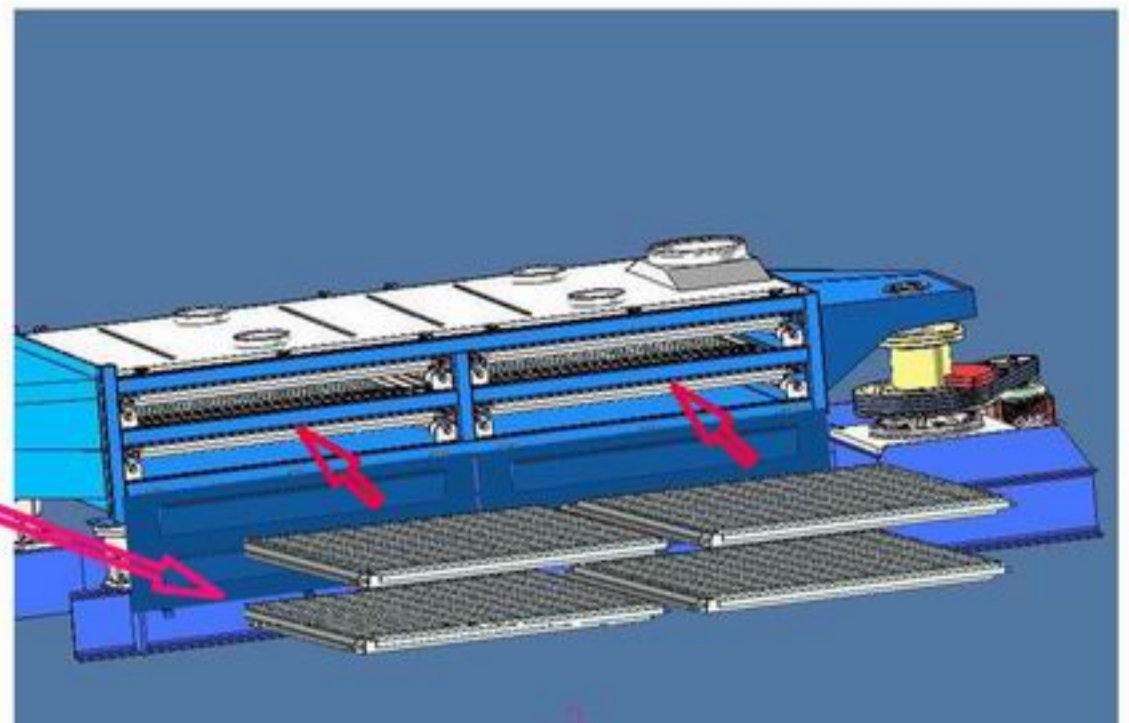
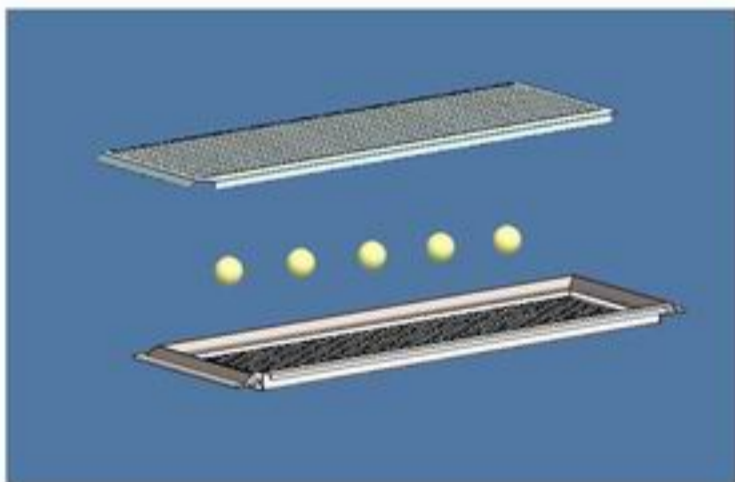

Open the side gate of the screen box, put into the screen deck along the fasten device, then rotary the fasten device to fix the screener deck, lock the side gate via fast clamp at last.

The whole operation process is simple and easy, and could save much time.

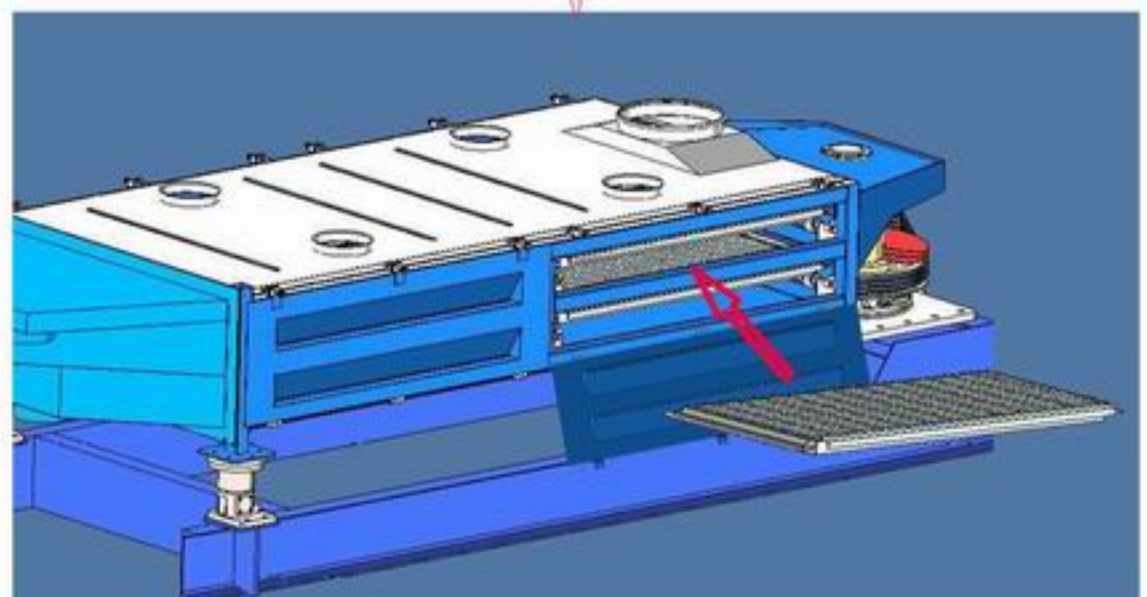

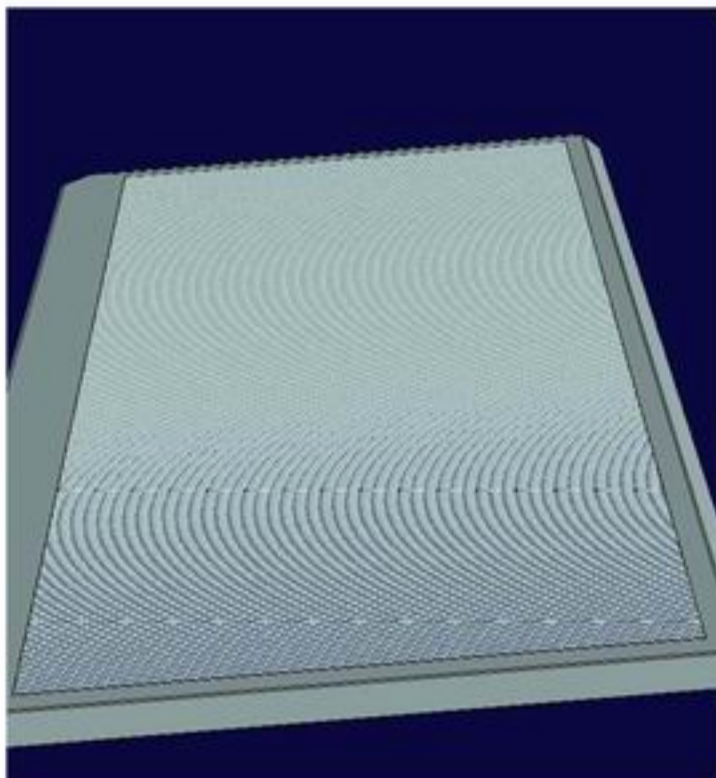

Each layer deck is one complete one for normal screener, but one layer deck could be divided into 2-8 independent little decks for MPG gyratory screener, so the area and weight of each little deck will be $1/8-1/2$ of one complete layer deck, so one operator could finish the work for changing mesh, and just need move out the worn out screener deck, it save the cost for maintenance and operation.

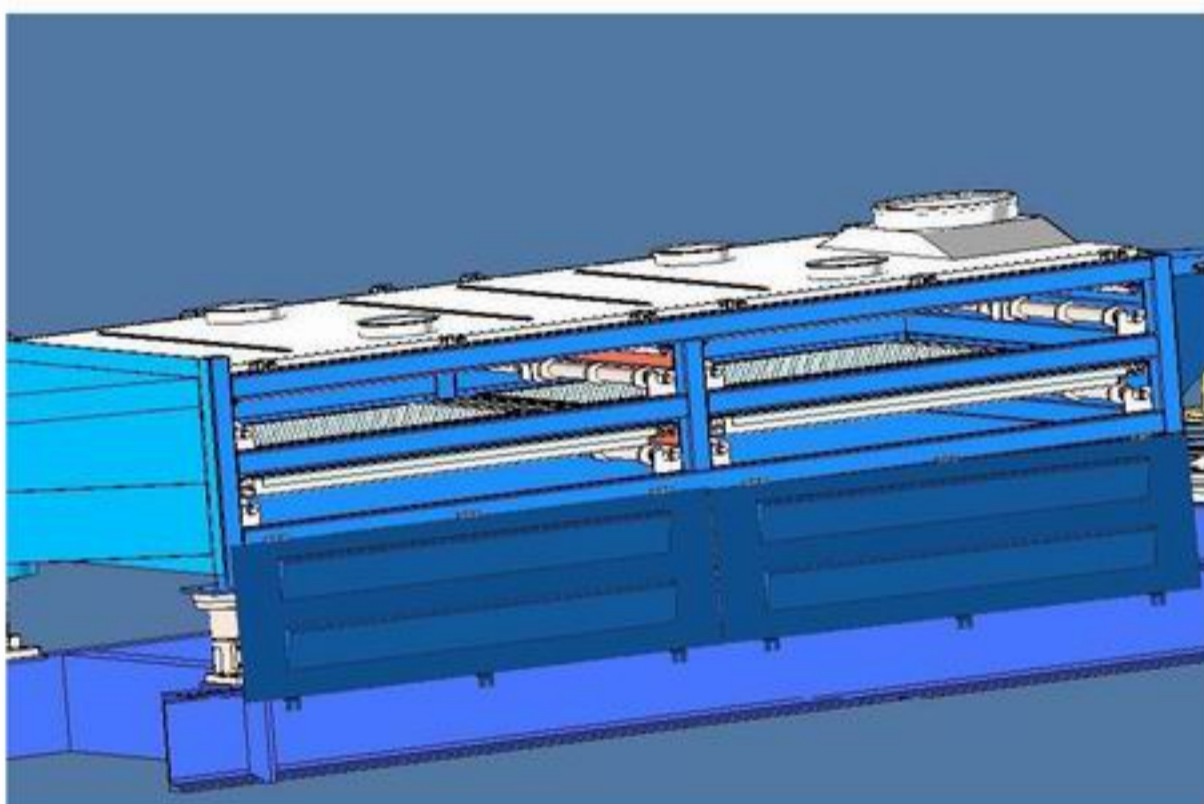
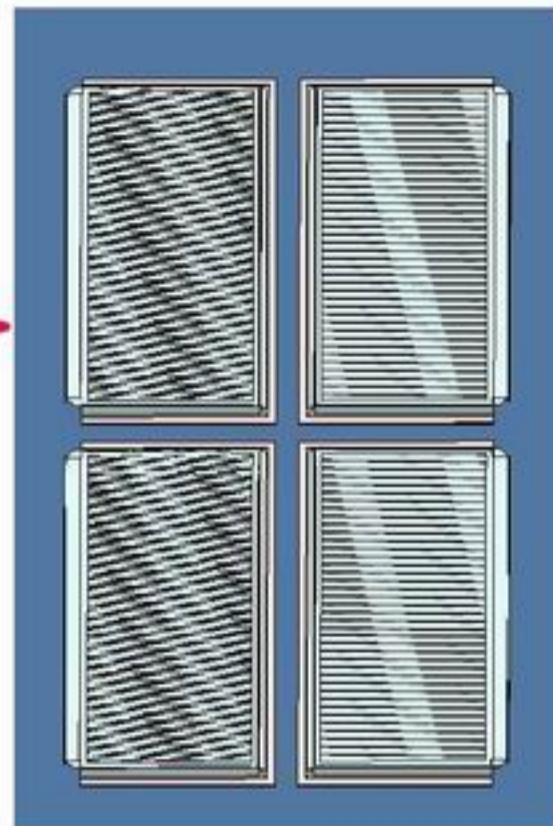

We do not move away the top cover when we maintain the MPG screener or change the screener mesh, just need open the side gate for maintenance or mesh changing. The side gate all is mount on the screener and we do not need removing the side gate. The operator do not need holding up the screener deck, we do not need moving upstream and downstream equipments and connections else. The top screener deck and bottom screener deck also is independent with each other, we also could change the bottom screen deck and do not remove the top screener deck. So the whole process is safe, do not do any extra work.

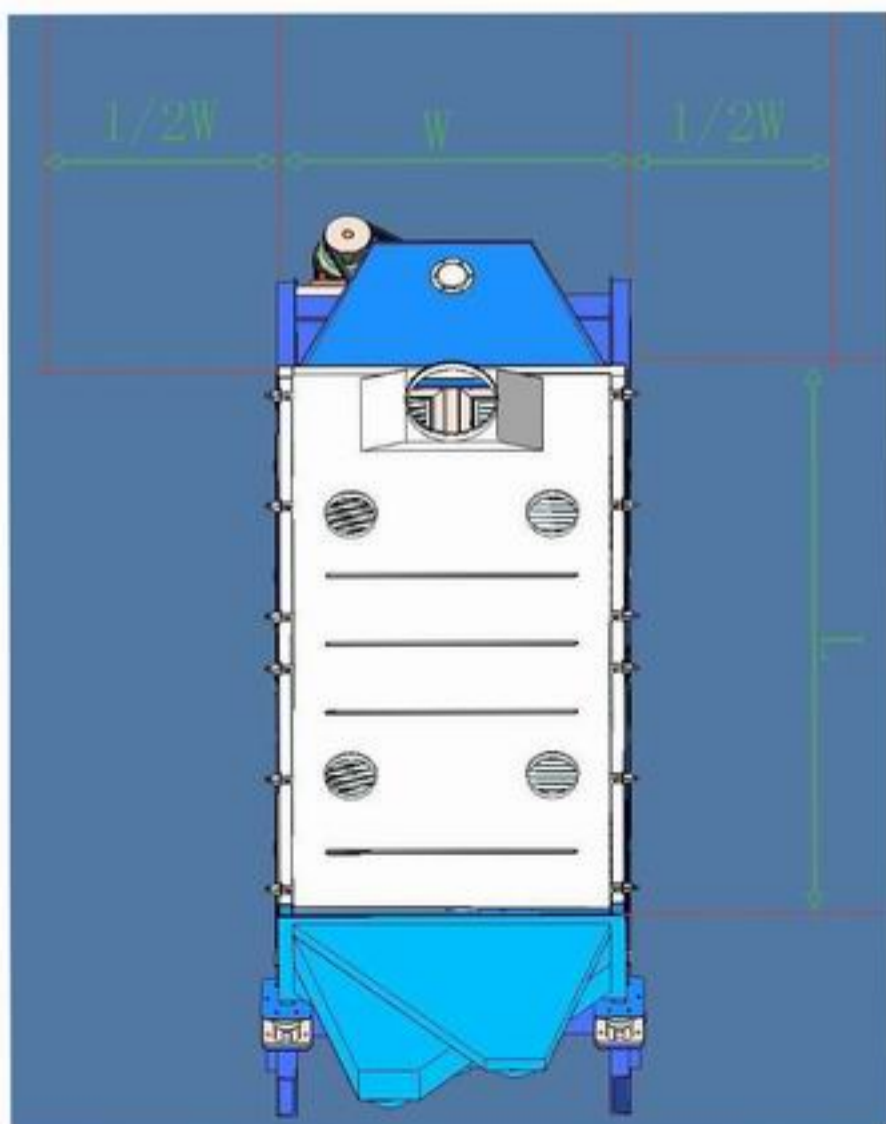

The screen deck is divided to two piece along the screener width direction, and it is also be divided into several equal little sections along the length direction, so the MPG screener with special deck structure could solve the problem if the installation room is limited. Because we could move out the screen deck from two side of the screener box at the same time, so do not keep too much room for guaranteeing the normal operation of renewing screen mesh. It divided into several sections along the material flow, so it do not keep too much room along the material flow direction. We release and renew the screener deck from two side of the screener, so do not keep room above and under the screen deck, it could save much installation room.

MPG Gyrotory screener parameter

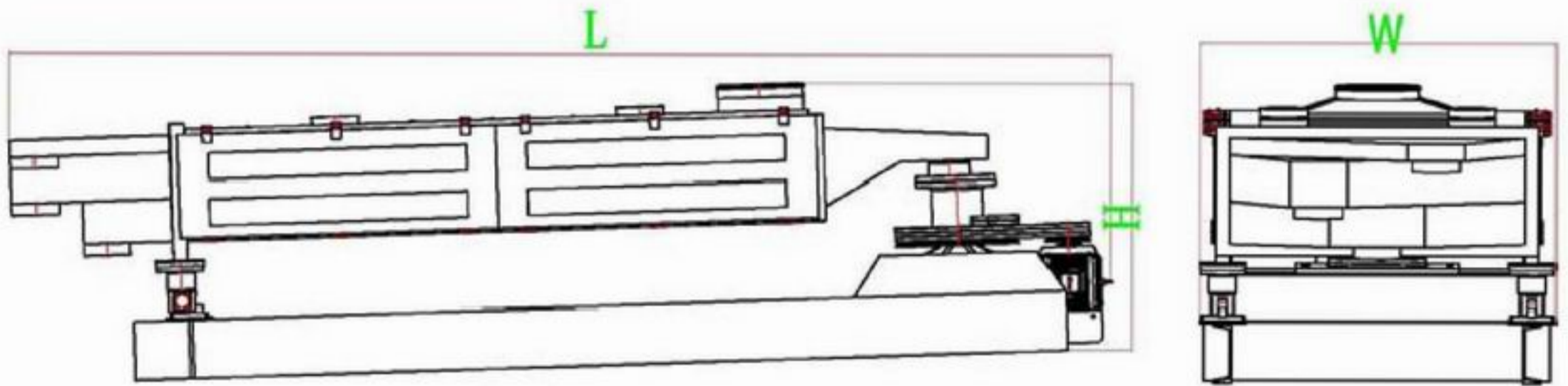

MPG TYPE GYRATORY SCREENER

	Model	Frequency	Amplitude	Capacity	Power	Outline (mm)			Weight
		r/min	mm	m ³ /h	kW	(L)	(W)		
1	MPG-A14	180-220	50	4~10	2.2	3477	1120	1326	1470
	MPG-B20	180-220	50	5~13	3	4065	1320	1326	1724
	MPG-C24	180-220	60	8~20	3	4463	1520	1333	1902
	MPG-D30	180-220	60	10~25	4	5095	1820	1340	2344
	MPG-E42	180-220	88	17~40	5.5	6293	2120	1345	3021
2	MPG-TC24	180-220	60	6~15	4	4463	1520	1508	2125
	MPG-TD30	180-220	60	8~18	4	5095	1820	1529	2446
	MPG-TE42	180-220	88	15~35	5.5	6293	2120	1532	3266
3	MPG-SC24	180-220	60	5~15	4	4715	1520	1706	2368
	MPG-SD30	180-220	60	8~18	5.5	4350	1820	1727	2860
	MPG-SE42	180-220	88	15~33	7.5	6545	2120	1730	3520



Chemical Material



Mineral/sand



Plastic



Recycling



Wooden dust

As one of our major production, we has sold hundreds sets of Gyratory screener to different industry application customer in the past over ten years, M series gyratory screener is widely used many industry such as chemical, agriculture, food, medicine, mineral, plastic and recycling industry etc, its steady working performance and high screening efficiency has been proven . MPG screener is similar with M gyratory screener, they could replace each other in many industry application.



Agriculture



Food

Material data

We could select the screener model base on our experience and calculation, but please offer us the following data as more as possible:

1. Material Name:

2. Feeding rate: T/H

3. Material density: KG/m³

4. Material moisture: %

5. Material temperature: °C

6. Surrounding temperature: °C

7. Deck Layer No.:

8. Aperture size of each deck: (Following is refer to three layers)

1st layer: mm 2^{ed} layer: mm 3rd layer: mm

9. Material size distribution (following is refer to 3 layers deck, fill it base on actual request):

Over 1st layer: % Between 1st layer and 2^{ed} layer: %

Between 2^{ed} and 3rd : % Under 3rd: %

10. Screen deck material: 9. Screener box material:

We could select the screener model for you base on above data, if you do not have above material data, we could do the material screening test if you post us the material.

Our service

The material screening test and capacity calculation
The equipment manufacture and quality control
The shop inspection before delivery
After-sale service
The complete equipment documents and record for customer's inquiry

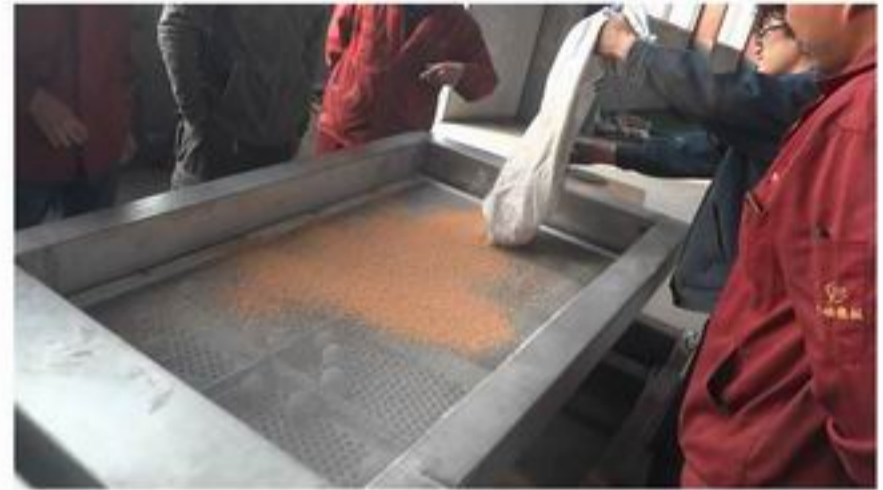

Material screening test, if it is first time to adopt gyratory screener for customer, or the customer is not familiar with the material characteristic, the customer could post us some material for material test screening, we could select the proper screening solution for you refer to the screening result .

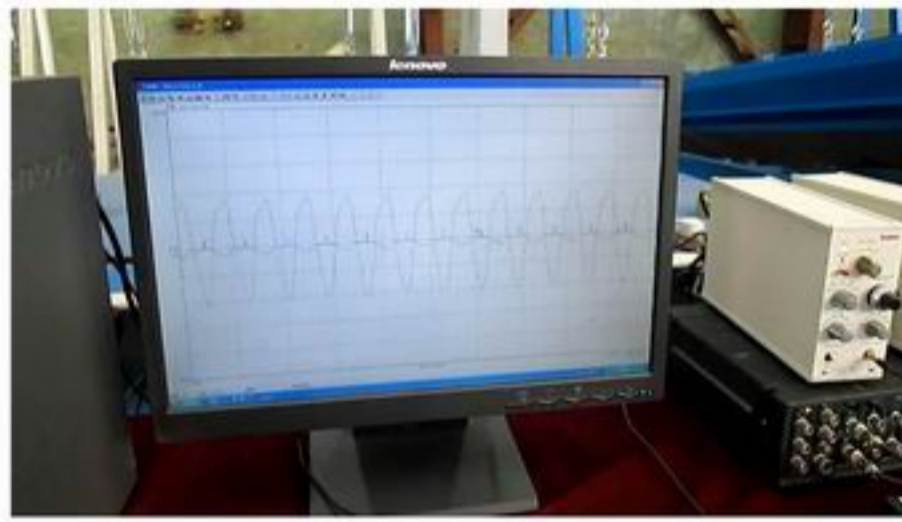

After equipment assembly work finished in workshop, our inspector will check every inspection item carefully include the noisy, temperature-up, frequency and amplitude etc so as to make sure every technical item could meet customer's request.

Some component may will be worn out after working for several weeks or months such as screen mesh, self-cleaning ball, the customer need renew the worn parts, if customers has demand on the spare parts, we will offer the specific parts as soon as possible.

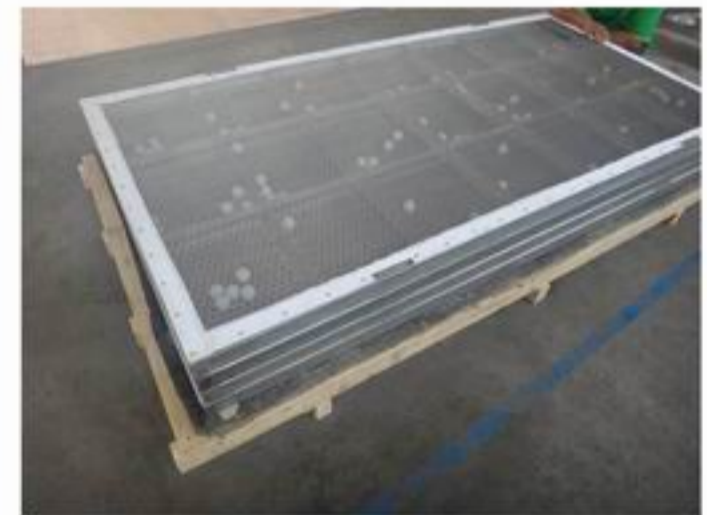

Effective service

We will prepare the complete production records for every screener, which could guarantee we could supply our customer assistance at once when customer need our after-sales service or need the production information.

Factory



MEGA YOUNG
兆扬



Gyratory screener for exportation in factory

